



INDUSTRIAL CHOICE



INDUSTRIAL CHOICE IC101 SS316 BALL VALVE

Reduced Port - One Piece - FNPT - 1000WP 1/4" to 2" in stock

-4F to 392F Locking Handle - Investment Casting - Blowout Proof Steam



10101

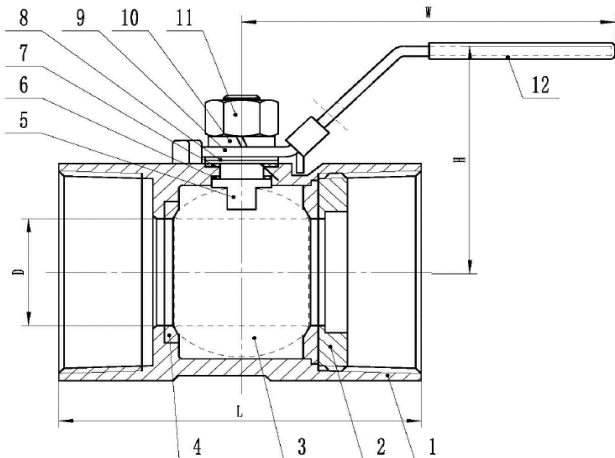

Item	Parts	Material		
1	Body	ASTM A351 CF8M	ASTM A351 CF8	ASTM A216 WCB
2	Cap	ASTM A351 CF8M	ASTM A351 CF8	ASTM A216 WCB
3	Ball	ASTM A351 CF8M	ASTM A351 CF8	ASTM A351 CF8
4	Seat	R-PTFE	R-PTFE	R-PTFE
5	Stem	ASTM A182 F316	ASTM A182 F304	ASTM A182 F304
6	Thrust Washer	R-PTFE	R-PTFE	R-PTFE
7	Packing	PTFE	PTFE	PTFE
8	Pin	304	304	304
9	Handle	304	304	304
10	Washer	301	301	301
11	Nut	304	304	304
12	Handle Sleeve	Plastic	Plastic	Plastic

FEATURES

- *Reduce Port
- *1000WOG Rating;
- *The thread ends conform to ANSI B1.20.1 (NPT) DIN2999 & BS 21 ISO 228/1 & ISO 7/1
- *Testing according to API-598
- *Investment casting

4"	65	195	120	215
3"	50	158	102	185
2-1/2"	38	128	84	185
2"	32	100	60	140
1-1/2"	25	83	54	140
1-1/4"	20	78	47	110
1"	15	72	43	110
3/4"	12.5	60	36	95
1/2"	9	56	33	95
3/8"	7	45	26	75
1/4"	5	39	24	65
Size	d	L	H	W

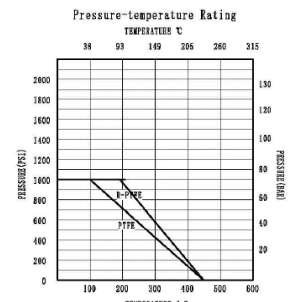

INDUSTRIAL CHOICE

IPC Screwed End Ball Valve 1000PSI

IC101